

小型中功率继电器

Miniature Intermediate Power Relay

5A

特性 / FEATURES

- 5A负载
Contact rating: 5A
- 体积小, 适用于高密度安装
Small size, suitable for high-density mounting
- 线圈与触点间介质耐压5kV
5kV dielectric strength(between coil and contacts)
- 具有两组常开、两组转换触点形式
2 From A and 2 From C configurations

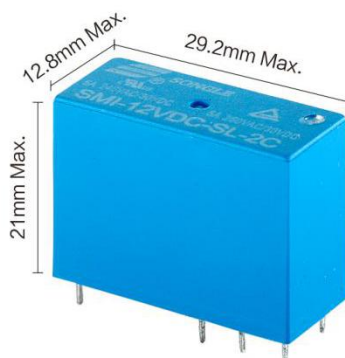

订购信息 / ORDERING INFORMATION

SMI-12VDC-S L-2C

2A/2C	触点形式 Contact Arrangement
L 0.54W / D 0.72W	线圈功率 Coil Power
S 密封/Sealed F 防焊剂/Flux proofed	封装形式 Construction
5/6/9/12/18/24/36/48VDC	线圈电压 Coil Voltage
	型号 Model

触点参数 / CONTACT PARAMETERS

触点形式	Contact arrangement	2A, 2C
接触电阻	Contact resistance	≤50mΩ (1A 6VDC)
触点材质	Contact material	银合金/Silver alloy: AgSnO ₂ In ₂ O ₃ 、AgSnO ₂ 、AgNi
触点负载(阻性)	Contact rating(Res. load)	5A 250VAC/30VDC
最大切换电压	Max switching voltage	277VAC/30VDC
最大切换电流	Max switching current	5A
最大切换功率	Max switching power	1385VA/150W
电耐久性 (频率:每小时360次)	Electrical endurance (Frequency:360 ops/h)	1×10 ⁵ ops / 1×10 ⁴ ops
机械耐久性 (频率:每小时18000次)	Mechanical endurance (Frequency:18000 ops/h)	1×10 ⁷ ops

SMI-2P^(14FD) Series

小型中功率继电器

Miniature Intermediate Power Relay

5A

特性参数 / CHARACTERISTICS PARAMETERS

绝缘等级	Insulation level			B/F
绝缘电阻	Insulation resistance			1000MΩ(500VDC)
介质耐压 (漏电流 1mA)	Dielectric strength (Leakage current 1mA)	线圈与触点间 Between coil and contacts	5000VAC 1min	
		触点组间 Between contacts sets	3000VAC 1min	
		断开触点间 Between open contacts	1000VAC 1min	
吸合时间(额定电压下)	Operate time(at nominal voltage)			≤15ms
释放时间(额定电压下)	Release time (without diode) (at nominal voltage)			≤5ms
湿度	Humidity			5% ~ 85% RH
环境温度(°C)	Ambient temperature			-40°C ~ +85°C
抗冲击	Shock resistance	稳定性/Functional	98m/s ²	
		强度/Destructive	980m/s ²	
抗振动(双振幅)	Vibration resistance (Double amplitude)			10Hz~55Hz 1.5mm
重量	Weight			约/Approx 15g
封装形式	Construction			密封/Sealed 防焊剂/Flux proofed

备注: 以上数据均为初始值

Remark: All above data is initial value

线圈参数 / COIL PARAMETERS

常温/At (23°C)

功耗(W)	Power consumption(W)	0.54W(L)								0.72W(D)							
		05	06	09	12	18	24	36	48	05	06	09	12	18	24	36	48
额定电压(VDC)	Nominal voltage(VDC)	46.3	66.7	150	267	600	1067	2400	4267	34.7	50	112.5	200	450	800	1800	3200
线圈电阻(Ω±10%)	Coil resistance(Ω±10%)																
吸合电压(Max)	Pick-up voltage(Max)	80% 额定电压(Nominal voltage)															
释放电压(Min)	Drop-out voltage(Min)	5% 额定电压(Nominal voltage)															
允许最大电压(VDC)	Max allowable overdrive voltage(VDC)	130% 额定电压(Nominal voltage)															

安全认证(相关认证以第三方认证证书为准) / SAFETY APPROVAL RATINGS



5A 250VAC

5A 250VAC
1A/3A 250VAC 感性/Inductive

5A 240VAC

小型中功率继电器

Miniature Intermediate Power Relay

5A

外形图 / OUTLINE DIMENSIONS

单位/Unit(mm)

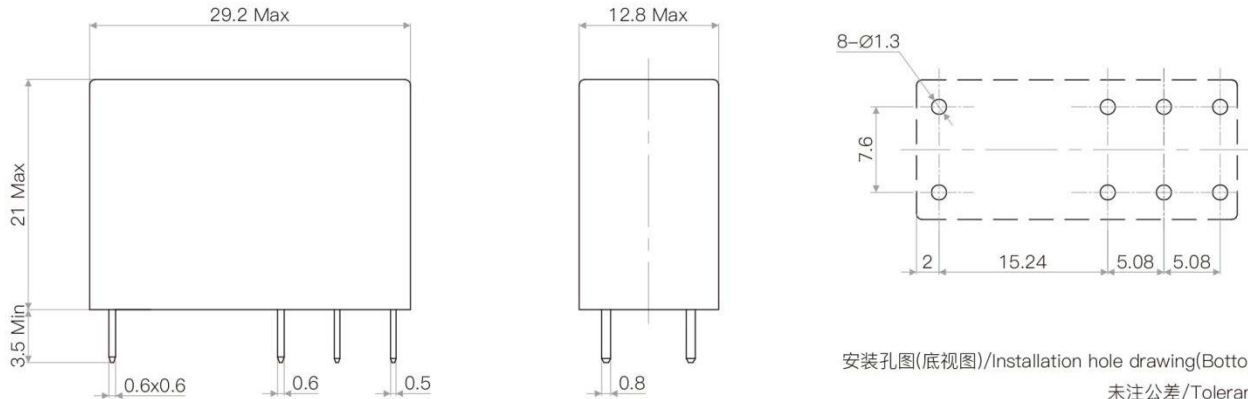

安装孔图(底视图)/Installation hole drawing(Bottom view)
未注公差/Tolerance:±0.1

线路图(底视图) / WIRING DIAGRAM (BOTTOM VIEW)

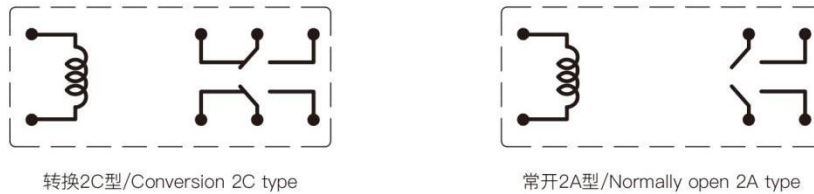

转换2C型/Conversion 2C type

常开2A型/Normally open 2A type

性能曲线图 / CHARACTERISTIC CURVES

